

SOLID JET MONITOR NOZZLE

SS316, 63 mm, AS PER IS:8442



Solid Jet nozzles are used as standard nozzles for fixed monitors in many countries, including India. It converts the pressure energy of water into velocity energy allowing water to be projected in form of a long range solid jet, which can be used for cooling and firefighting. Solid jet nozzles are designed for operation at an optimum pressure.

Brief Description : AAAG Solid Jet nozzle for monitors, made of Stainless Steel (SS316), suitable for 63 mm waterway size monitor, nominal outlet bore 32 mm, having flow of 1750 lpm (min) at 7 kgf/cm² inlet pressure, and giving superior range jet. Nozzle shall have suitable inlet matching to monitor threads

1.0 GENERAL DATA

1.1	Make	AAAG
1.2	Model	Solid Jet Nozzle
1.3	Inlet	Threaded 2.5" BSP (Female)
1.4	Outlet	Solid bore, 32 mm dia. (min)
1.5	Material of Construction	Stainless Steel (SS316)
1.6	Reference	IS:8442

2.0 MATERIAL OF CONSTRUCTION

2.1	Nozzle	SS316, IS:3444 Gr. IV
2.2	Washer	Rubber (Natural)

3.0 TESTING AND QUALITY CONTROL

3.1	Dimensional check	As per Drawing No. SBJ/ (see below)
3.2	Documentation	Internal inspection report, supplier's certificates, approved laboratory test certificates

4.0 OPERATIONAL/ TECHNICAL DATA

4.1	Working pressure	5 to 12 Kgf/cm ² (optimum 7 kgf/cm ²)
4.2	Discharge Pattern	Solid Jet stream.
4.3	Weight (approx.)	3.0 Kgs

5.0 FINISH

5.1	Nozzle	Natural finish/Polished
-----	--------	-------------------------

6.0 APPROVALS & MARKING

6.1	Approvals	--
6.2	Marking on Nozzle	AAAG/ Year of Manufacture/ Size of Nozzle

7.0 WARRANTY

7.1	Warranty & Guarantee	12 Months from the date of supply
-----	----------------------	-----------------------------------

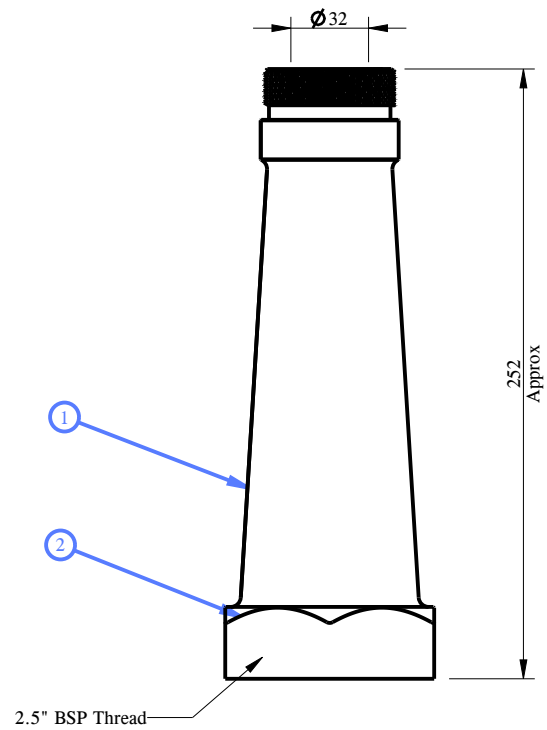

NOTES :

01. PERFORMANCE TEST :- DISCHARGE CAPACITY :

1750 LPM @ 7KGF/CM2
54 Mtrs.Horizontal Throw Water At 30° Trajectory In Still Wind Condition.

NO	DESCRIPTION	MATERIAL
1	Nozzle	SS 316 IS:3444 Gr.4
2	Washer	Rubber (Nature)

PART LIST



Shah Bhogilal Jethalal & Bros.

AHMEDABAD

TITLE :
Solid Jet Monitor Nozzle, 1750 Lpm
Capacity, SS 316, As Per IS: 8442

SCALE	DRAWING NO:	SHEET	REV.
N.T.S	SM119-63AS	1 OF 1	0