

# SUCTION HOSE COUPLING

GUNMETAL, 75 mm, CONVENTIONAL



Suction Hose Couplings are connected to suction hoses using binding (with Copper/GI wire) or clamps, and allow connection of hoses to pumps, strainers, fittings, etc having similar threads. Suction couplings consist of Male and Female threaded parts, and have a serrated tail portion, on which the hose is mounted.

**Brief Description** : AAAG Suction Hose Male/ Female Couplings, 75 mm size, Conventional Design, made of Gunmetal, suitable for use with hard suction hoses. Couplings shall have standard round threads.

## 1.0 GENERAL DATA

1.1	Make	AAAG
1.2	Size	75 mm
1.3	Type	Threaded (75 mm Round Threads)
1.4	Hose Connection	Shank 75 mm size
1.5	Material of Construction	Gunmetal
1.6	Reference	--

## 2.0 MATERIAL OF CONSTRUCTION

2.1	Female Coupling (shank)	Gunmetal, IS:318 LTB-2
2.2	Nut for Female Coupling	Gunmetal, IS:318 LTB-2
2.3	Male Coupling	Gunmetal, IS:318 LTB-2
2.5	Washer	Rubber IS:937 Type A

## 3.0 TESTING AND QUALITY CONTROL

3.1	Dimensional check	See drawing below
3.2	Hydrostatic Pressure Test	21 kgf/cm <sup>2</sup> for 2.5 minutes
3.3	Documentation	Internal inspection report, supplier's certificates, approved laboratory test certificates

## 4.0 OPERATIONAL/ TECHNICAL DATA

4.1	Working Pressure Range	5 to 12 Kgf/cm <sup>2</sup>
4.2	Weight (approx.)	2.5 Kgs. (approx)

## 5.0 FINISH

5.1	Coupling	Polished
-----	----------	----------

## 6.0 APPROVALS & MARKING

6.1	Approvals	--
6.2	Marking	AAAG/ Year of Mfg./SI No

## 7.0 WARRANTY

7.1	Warranty & Guarantee	12 Months from the date of supply
-----	----------------------	-----------------------------------

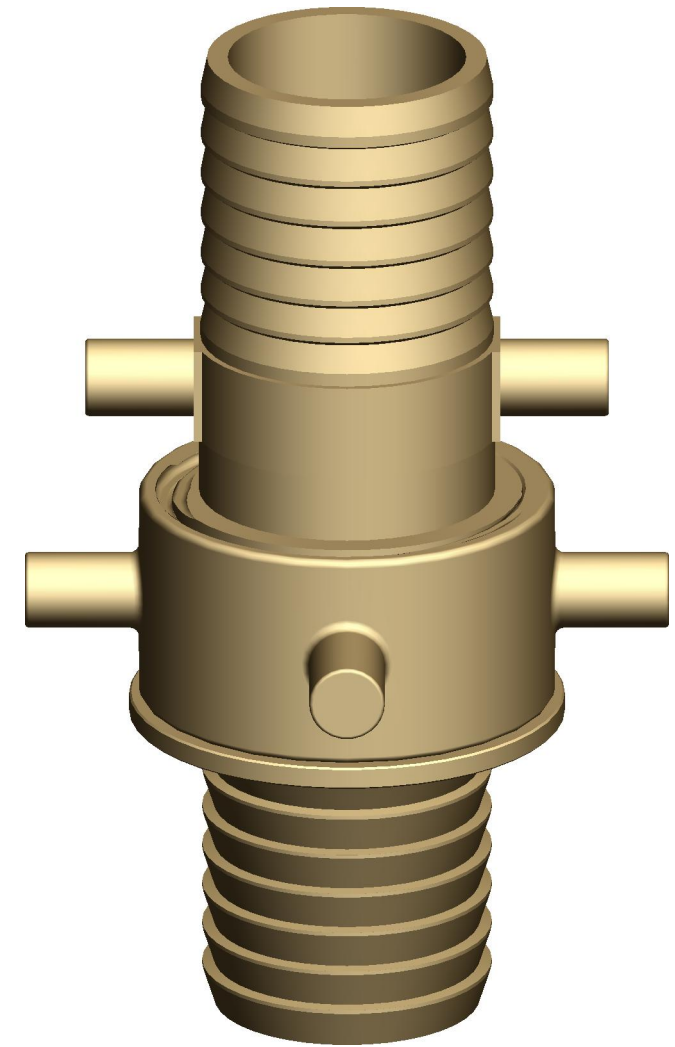
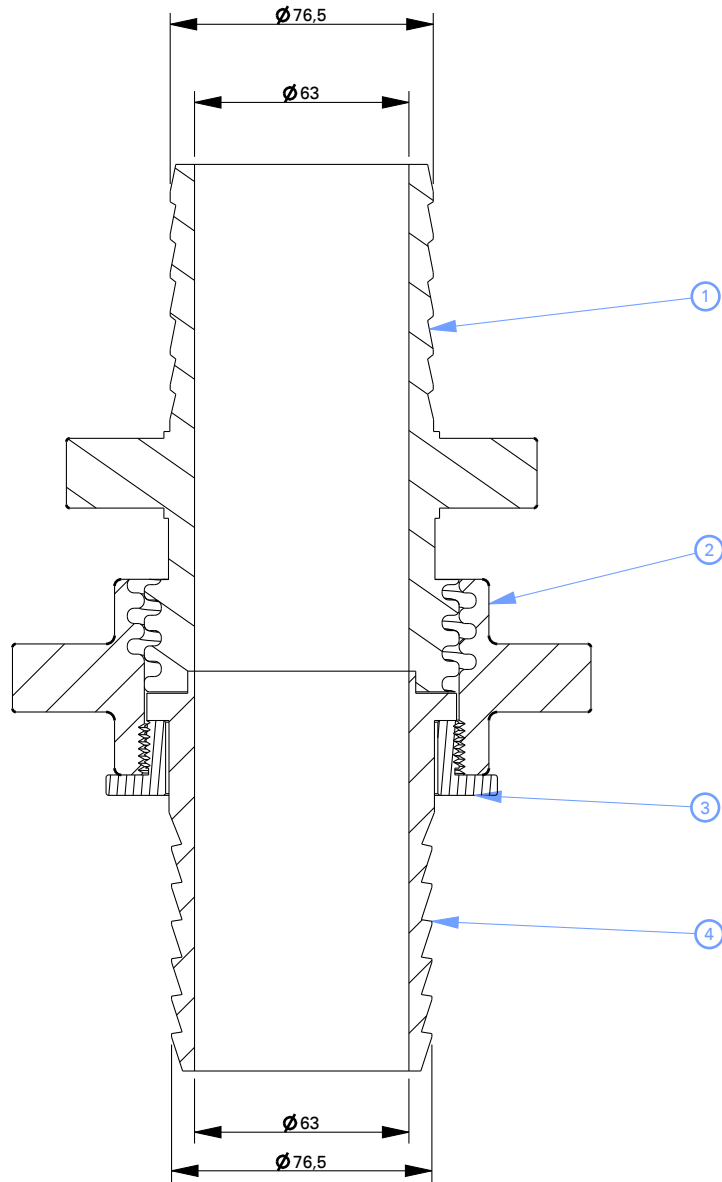

1	Female Coupling	G.M IS:318 LTB-2
2	Nut For Female Coupling	G.M IS:318 LTB-2
3	Locking Nut	G.M IS:318 LTB-2
4	Male Coupling	G.M IS:318 LTB-2
NO	DESCRIPTION	MATERIAL
PART LIST		



**Shah Bhogilal Jethalal & Bros.**

AHMEDABAD

**TITLE :** Suction Hose Coupling, Round Thread  
(75 mm), Gunmetal, Conventional Design

SCALE	DRAWING NO:	SHEET	REV.
N.T.S	G141-75CL	1 OF 1	0