

ADAPTOR

SS316, 75 mm, MALE ROUND THREADS x MALE BSP THREADS



Adaptors allow connection of delivery or suction hoses to different fittings/equipment, which have a dissimilar connecting arrangement, e.g. connecting hoses to equipment having threaded connections, connecting instantaneous hose couplings to flanged equipment, connecting hoses having similar couplings, or hoses of two different sizes, etc.

Brief Description : AAAG Male Round Thread (75 mm) x Male Thread (BSP, 75 mm) Adaptor, made of Stainless Steel (SS316), suitable for use with Firefighting equipment/systems having matching Female BSP threads (75 mm). Male Round Threads shall be matching to standard Female Round threads (75 mm size). Lugs shall be provided for easy tightening of adaptor.

1.0 GENERAL DATA

1.1	Make	AAAG
1.2	Size	75 mm
1.3	Inlet	Male Round Thread (75 mm)
1.4	Outlet	Male BSP Thread (75 mm)
1.5	Material of Construction	Stainless Steel (SS316)
1.6	Reference	--

2.0 MATERIAL OF CONSTRUCTION

2.1	Adaptor	SS316, IS:3444 Grade IV
-----	---------	-------------------------

3.0 TESTING AND QUALITY CONTROL

3.1	Dimensional check	See drawing below
3.2	Hydrostatic Pressure Test	21 kgf/cm ² for 2.5 minutes
3.3	Documentation	Internal inspection report, supplier's certificates, approved laboratory test certificates

4.0 OPERATIONAL/ TECHNICAL DATA

4.1	Working Pressure Range	upto 14 Kgf/cm ²
4.2	Weight (approx.)	---

5.0 FINISH

5.1	Adaptor	Polished
-----	---------	----------

6.0 APPROVALS & MARKING

6.1	Approvals	--
6.2	Marking	AAAG/ Year of Mfg./SI No

7.0 WARRANTY

7.1	Warranty & Guarantee	12 Months from the date of supply
-----	----------------------	-----------------------------------

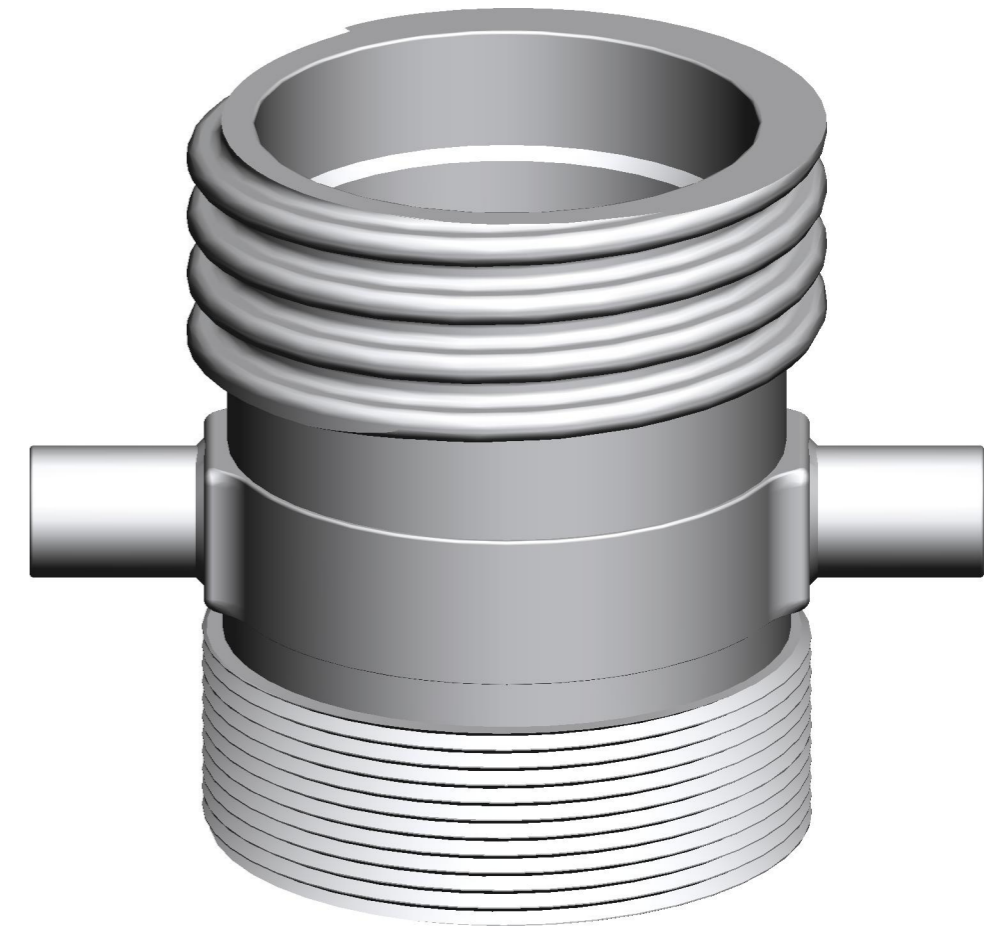
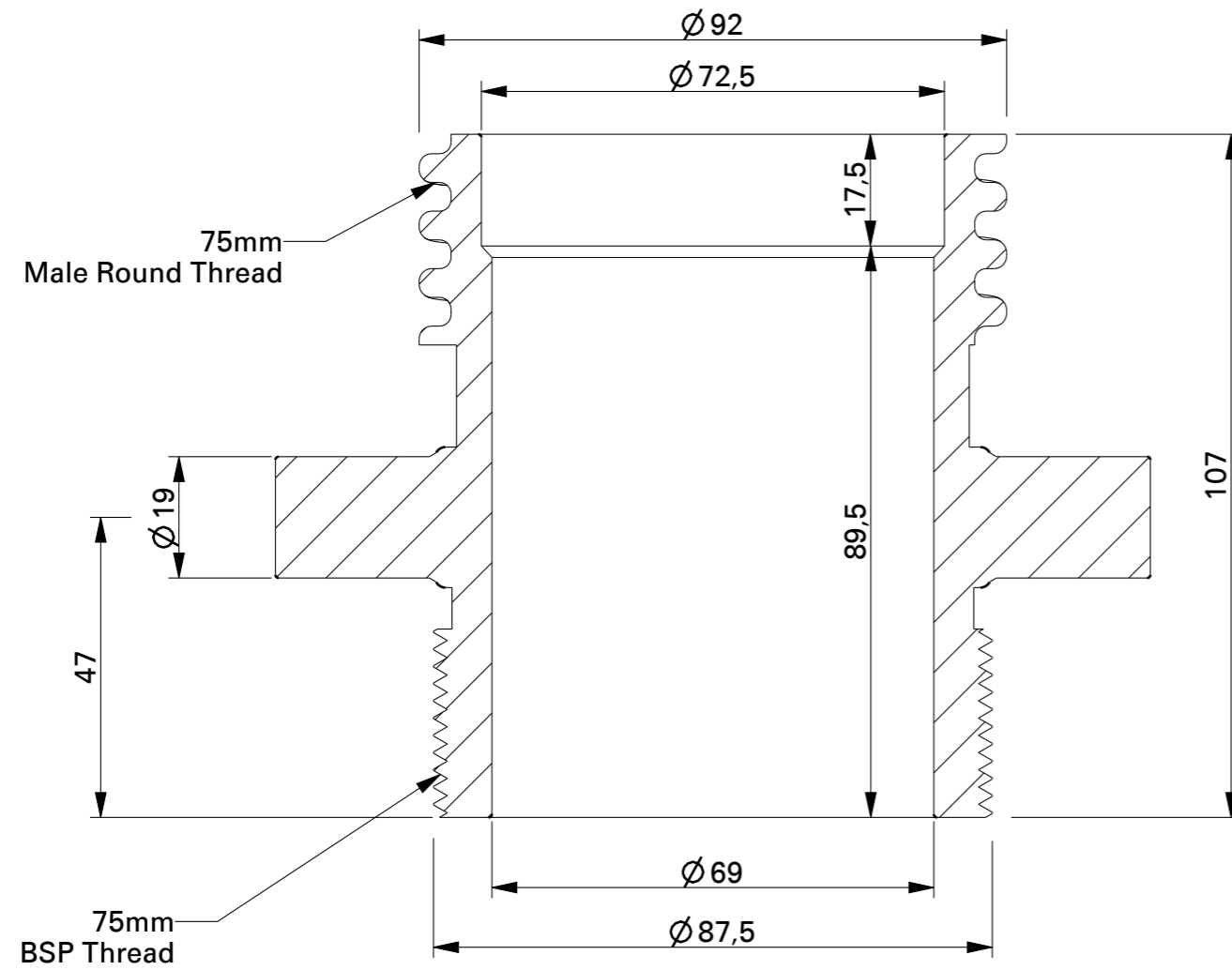

Shah Bhogilal Jethalal & Bros.

AHMEDABAD

TITLE :

Male Round Thread (75 mm) x Male Threaded
(BSP, 75 mm) Adaptor, SS 316

SCALE

N.T.S

DRAWING NO:

SM177-75BJ

SHEET

1 OF 1

REV.

0