

FOAM MONITOR

SS316, 500-750 GPM, UL LISTED



Foam monitors (Unaspirated foam) are used for protection of flammable liquid hazards and produce superior, long reaching foam streams. These monitors can be used for water or foam application, depending upon the situation, and can be fixed onto standposts, towers or custom-built trailers. In variable flow monitor, flow can be varied to obtain optimal performance.

Brief Description : AAAG Foam monitor, Variable Flow, UL Listed, nominal flow capacity 500/750 gpm at 7 kg/cm² inlet pressure. Monitor shall be constructed of Stainless Steel (SS316), with Geared Swivel Joints fitted with Handwheels, suitable inlet flange and variable foam nozzle with above flow settings. Monitor shall give good hydraulic performance and range.

1.0 GENERAL DATA

1.1	Make	AAAG
1.2	Model	Foam Monitor, UL Listed, 500-750 gpm
1.3	Inlet	Flanged - 100 NB, ANSI B16.5 150#
1.4	Outlet	Threaded, matching to Foam Nozzle
1.5	Material of Construction	Stainless Steel (SS316)
1.6	Reference	UL 162

2.0 MATERIAL OF CONSTRUCTION

2.1	Base Flange	SS316
2.2	Reducer/Pipe/Bends	SS316
2.3	Swivel Joints	SS316
2.4	Handwheel	SS316
2.5	Nozzle	SS316
2.6	Pick-Up Tube	PVC Helical, Non-collapsible

3.0 TESTING AND QUALITY CONTROL

3.1	Dimensional check	See drawing below
3.2	Hydrostatic Pressure Test	25 kgf/cm ² for 5 minutes (Monitor only)
3.3	Performance Requirements	<u>Flow test with Foam monitor at approx. 30^o, in still wind conditions</u> Flow: 500/750 gpm at 7 kg/cm ² , Foam Range 45/55 Mtrs (min), Foam expansion: 1:3 to 1:4 (min) with UL Listed Foam concentrate.
3.4	Documentation	Internal inspection report, supplier's certificates, approved laboratory test certificates

4.0 OPERATIONAL/ TECHNICAL DATA

4.1	Working pressure	5 to 14 Kg/cm ²
4.2	Manouverability	+90 ^o / -45 ^o in vertical plane, 360 ^o in horizontal plane
4.3	Weight (approx.)	---

5.0 FINISH

5.1	Body	Painted - Fire Red Color
5.2	Handwheels	Painted - Black Color
5.3	Nozzle	Polished

6.0 APPROVALS & MARKING

6.1	Approvals	UL Listed (EX6995)
6.2	Marking on Nozzle	Model/ Capacity/ Year of Mfg./ Sl. No/ UL mark

7.0 WARRANTY

7.1	Warranty & Guarantee	12 Months from the date of supply
-----	----------------------	-----------------------------------

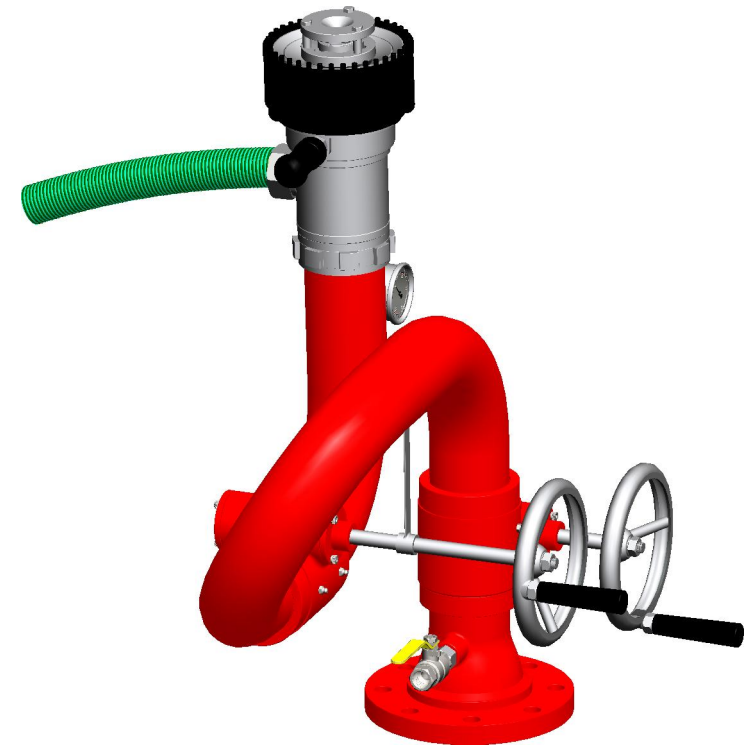
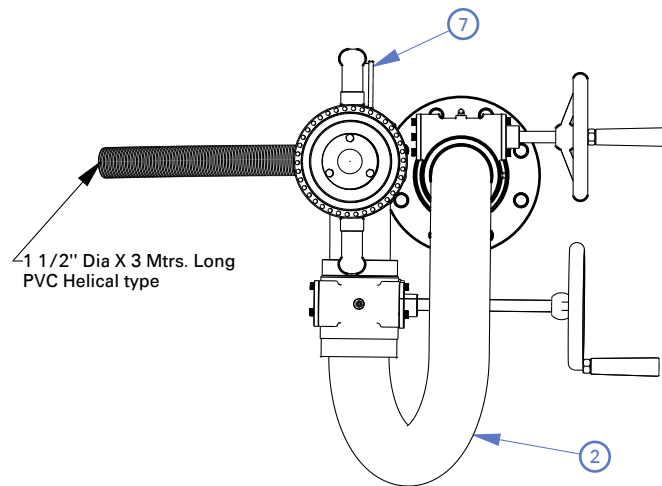
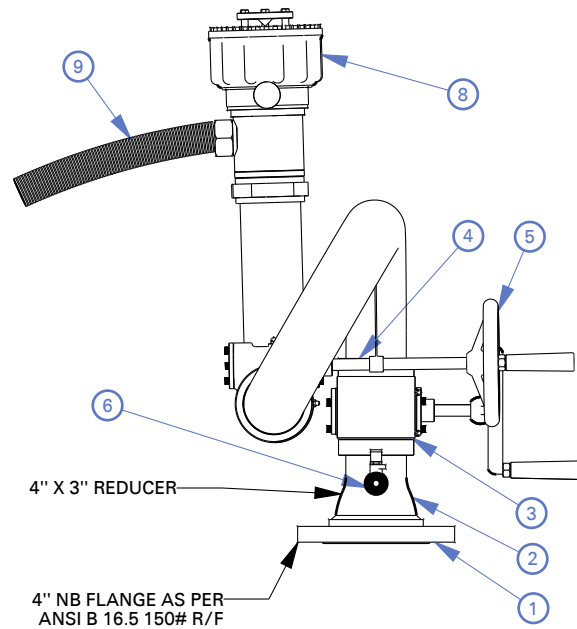

NOTES:

- 01. **PERFORMANCE REQUIREMENTS IN STILL WIND CONDITION:**
 - > 500 GPM (1890 LPM)
WATER THROW AT 30°-50 Mtr.
FOAM THROW AT 30°-45 Mtr.
 - > 750 GPM (2850 LPM)
WATER THROW AT 30°-60 Mtr.
FOAM THROW AT 30°-55 Mtr.
- 02. **HYDROSTATIC PRESSURE TEST:**
(FOR MONITOR) 25 KGF/CM2 (FOR 2.5 MINUTES)
- 03. **ROTATION:**
360° IN EITHER DIRECTION IN THE HORIZONTAL PLANE & 135° IN THE VERTICAL PLANE (+90°, -45°)

1	INLET FLANGE	SS 316
2	REDUCER/PIPES/BENDS	SS 316
3	SWIVEL JOINT	SS 316
4	WORM	SS 316
5	HAND WHEEL	SS 316
6	DRAIN VALVE	SS 316
7	PRESSURE GAUGE	S.S
8	AQUA FOAM NOZZLE	SS 316
9	PICK UP TUBE	PVC
NO.	DESCRIPTION	MATERIAL
PART LIST		



Shah Bhogilal Jethalal & Bros.

AHMEDABAD

TITLE : Foam Monitor , 500-750 GPM Capacity
SS 316 , UL Listed

SCALE	DRAWING NO:	SHEET	REV.
N.T.S	SM196V-75UL	1 OF 1	0