

## FOAM MONITOR

SS316, 500 GPM, UL LISTED



Foam monitors (Unaspirated foam) are used for protection of flammable liquid hazards and produce superior, long reaching foam streams. These monitors can be used for water or foam application, depending upon the situation, and can be fixed onto Monitor posts, towers or on custom-built trailers. Monitors can also be fitted with Remote Control Mechanism.

**Brief Description :** AAAG Foam monitor, UL Listed, nominal flow capacity 500 gpm (1890 lpm) at 7 kg/cm<sup>2</sup> inlet pressure. Monitor shall be constructed of Stainless Steel (SS316), with Geared Swivel Joints fitted with Handwheels, shall have suitable inlet flange and fitted with foam nozzle of above capacity. Monitor shall give good hydraulic performance and range.

### 1.0 GENERAL DATA

1.1	Make	AAAG
1.2	Model	Foam Monitor, UL Listed, 500 gpm (Self Induction)
1.3	Inlet	Flanged - 100 NB, ANSI B16.5 150#
1.4	Outlet	Threaded, matching to Foam Nozzle
1.5	Material of Construction	Stainless Steel (SS316)
1.6	Reference	UL 168

### 2.0 MATERIAL OF CONSTRUCTION

2.1	Base Flange	SS316
2.2	Reducer/Pipe/Bends	SS316
2.3	Swivel Joints	SS316
2.4	Handwheel	SS316
2.5	Nozzle	SS316
2.6	Pick-Up Tube	PVC Helical, Non-collapsible

### 3.0 TESTING AND QUALITY CONTROL

3.1	Dimensional check	See drawing below
3.2	Hydrostatic Pressure Test	25 kgf/cm <sup>2</sup> for 5 minutes (Monitor only)
3.3	Performance Requirements	<u>Flow test with Foam monitor at approx. 30<sup>o</sup>, in still wind conditions</u> Flow: 500 gpm at 7 kg/cm <sup>2</sup> , Foam Range 45 Mtrs (min), Foam expansion: 1:3 to 1:4 (min) with UL Listed Foam concentrate
3.4	Documentation	Internal inspection report, supplier's certificates, approved laboratory test certificates

### 4.0 OPERATIONAL/ TECHNICAL DATA

4.1	Working pressure	5 to 14 Kg/cm <sup>2</sup>
4.2	Manouverability	+90 <sup>o</sup> / -45 <sup>o</sup> in vertical plane, 360 <sup>o</sup> in horizontal plane
4.3	Weight (approx.)	---

### 5.0 FINISH

5.1	Body	Painted - Fire Red Color
5.2	Handwheels	Painted - Black Color
5.3	Nozzle	Polished

### 6.0 APPROVALS & MARKING

6.1	Approvals	UL Listed (EX6995)
6.2	Marking on Nozzle	Model/ Capacity/ Year of Mfg./ Sl. No/ UL mark

### 7.0 WARRANTY

7.1	Warranty & Guarantee	12 Months from the date of supply
-----	----------------------	-----------------------------------

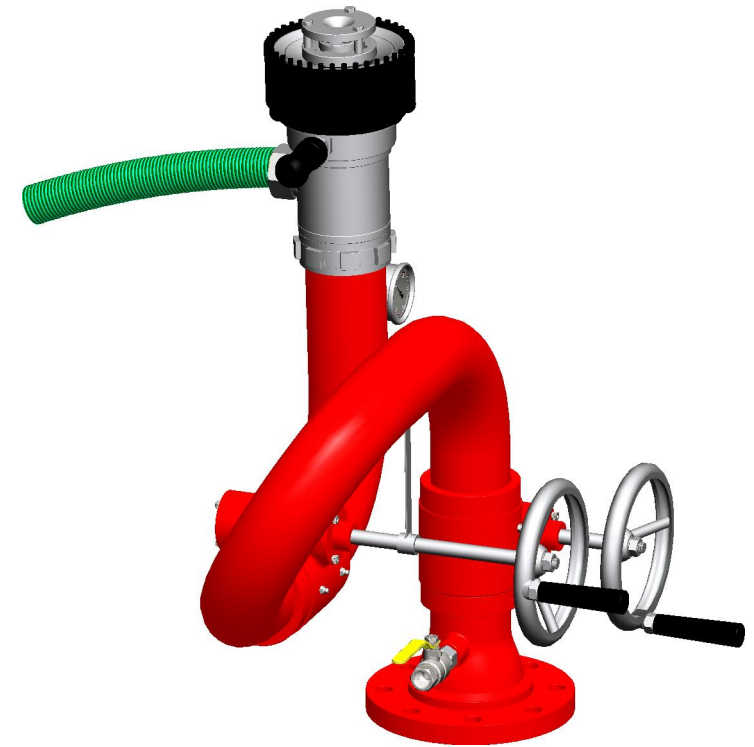
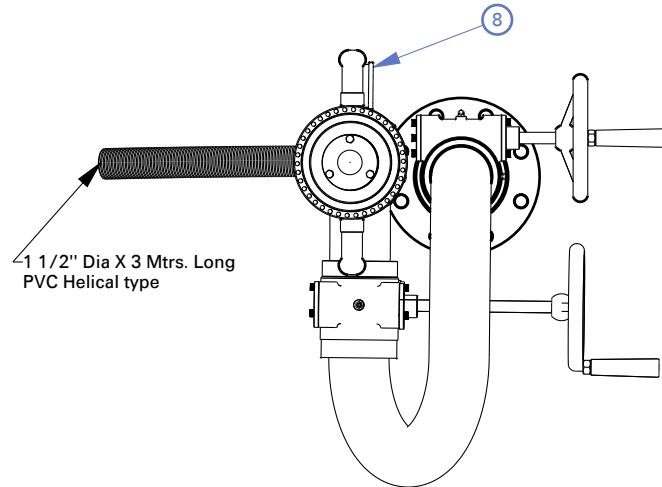
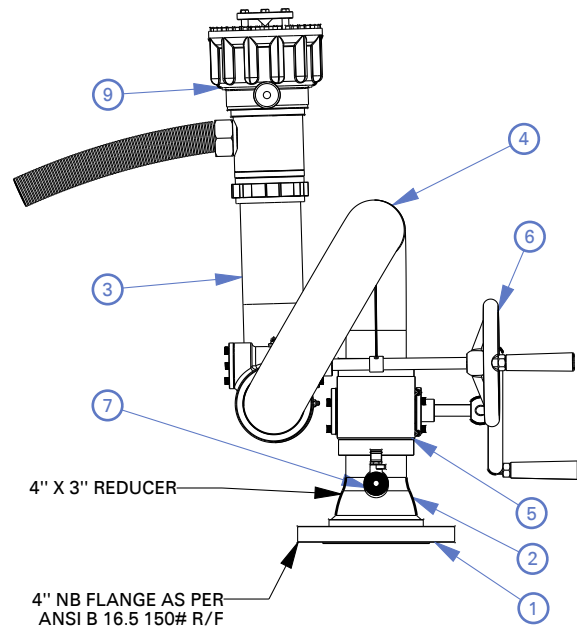

**NOTES:**

01. **PERFORMANCE REQUIREMENTS:**  
1890 LPM ( 500 US GPM) FLOW AT A PRESSURE OF 7 KG/CM2, WITH 50 Mtrs. (WATER) AND 45 Mtrs. (FOAM) HORIZONTAL THROW AT 30° TRAJECTORY. (IN STILL WIND CONDITIONS)
02. **HYDROSTATIC PRESSURE TEST:**  
(FOR MONITOR) 25 KGF/CM2 (FOR 2.5 MINUTES)
03. **ROTATION:**  
360° IN EITHER DIRECTION IN THE HORIZONTAL PLANE & 135° IN THE VERTICAL PLANE (+90°, -45°)

1	INLET FLANGE	SS 316
2	REDUCER	SS 316
3	PIPE	SS 316
4	BENDS	SS 316
5	SWIVEL JOINT	SS 316
6	HAND WHEEL	SS 316
7	DRAIN VALVE	S.S
8	PRESSURE GAUGE	S.S
9	AQUA FOAM NOZZLE	SS 316
<b>NO.</b>	<b>DESCRIPTION</b>	<b>MATERIAL</b>
<b>PART LIST</b>		



**Shah Bhogilal Jethalal & Bros.**

AHMEDABAD

**TITLE :** Foam Monitor, 500 GPM Capacity,  
SS 316, UL Listed

SCALE	DRAWING NO:	SHEET	REV.
N.T.S	SM196-63UL	1 OF 1	0