

HYDRANT VALVE (SINGLE OUTLET)**GUNMETAL, MMD APPROVED**

Hydrant valves (also called Landing valves) provide the means to draw water for firefighting from the Fire water piping network. They are normally mounted onto stand posts, fitted on the fire water network.

Brief Description : Hydrant Valve – Type A, as per IS:5290, MMD approved, made of Gun Metal, having 75 mm flanged inlet, and 63 mm Female Instantaneous outlet, provided with C.I. handwheel for operation, and PVC blank cap with chain. Body duly painted with 2 coats of superior quality paint. H.P. tested to 21 kgf/cm² (body) and 14 kgf/cm² (seat). Flow 900 lpm (min) at 7 kgf/cm².

1.0 GENERAL DATA

1.1	Make	AAAG
1.2	Size	63 mm
1.3	Inlet – Flanged	80/ 75 NB, IS: 1538 / ANSI B 16.5 150 #
1.4	Outlet	63mm Female Inst. Adaptor
1.5	Reference Standard	IS: 5290 TYPE A

2.0 MATERIAL OF CONSTRUCTION

2.1	Body, Bonnets, Female outlet and parts	G.M. IS: 318 LTB-2
2.2	Spindle	Brass IS: 319
2.3	Spring	Phosphor Bronze Wire IS: 7608
2.4	Hand Wheel	C.I. IS: 210 FG 200
2.5	Washer	Rubber IS: 937 Type A

3.0 TESTING AND QUALITY CONTROL

3.1	Dimensional check	Dimensions as per IS:5290 Type A (See drawing below)
3.2	Water Tightness Seat Test	14 kgf/cm ² for 2.5 minutes.
3.3	Hydrostatic Pressure Test	21 kgf/cm ² for 2.5 minutes.
3.4	Performance requirements	Flow test : 900 lpm (min) at 7 kg/cm ² pressure
3.5	Documentation	Internal inspection report, supplier's certificates, approved laboratory test certificates

4.0 OPERATIONAL/ TECHNICAL DATA

4.1	Working pressure range	upto 10 Kg/cm ²
4.2	Weight (approx.)	9.0 Kgs.

5.0 FINISH

5.1	Body	Painted - Fire Red Color as per IS: 5 Shade No. 536
5.2	Wheel	Painted - Black Paint
5.3	Parts	Polished

6.0 APPROVALS & MARKING

6.1	Approvals	MMD Approved
6.2	Marking on Hydrant valve	BHOJEBROS / Size/ Year of Manufacture/ Sl. No

6.0 WARRANTY

6.1	Warranty & Guarantee	12 Months from the date of supply
-----	----------------------	-----------------------------------

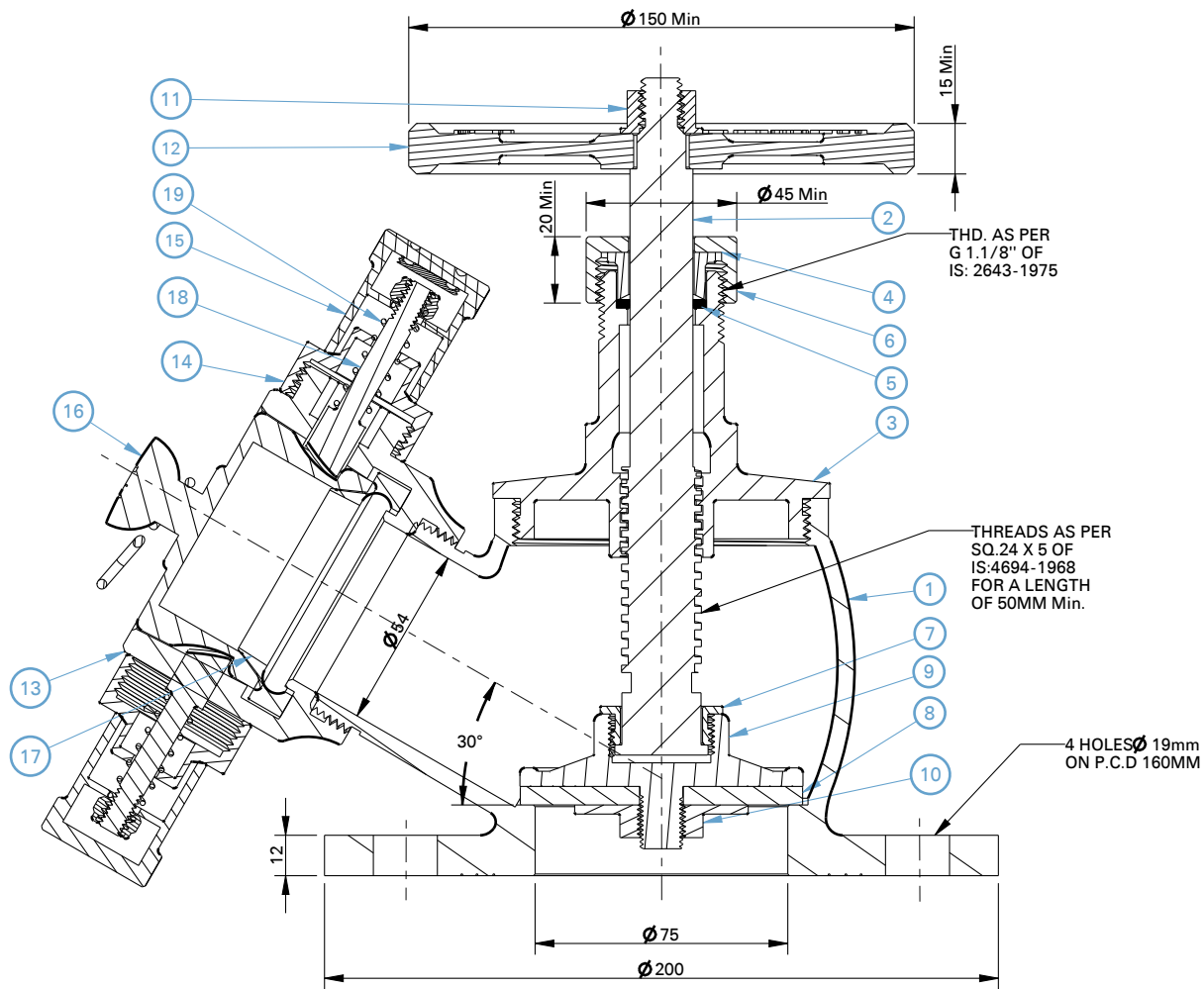

HYDRAULIC TEST:

SEAT TIGHTNESS	:14KGF/CM2. (FOR 2.5 MINUTES)
BODY	:21KGF/CM2. (FOR 2.5 MINUTES)
FLOW TEST	:900 LPM MIN @ 7KGF / CM2.

NO.	DESCRIPTION	MATERIAL	NO.	DESCRIPTION	MATERIAL
1	BODY	GM IS:318 LTB 2	11	HEX.NUT	M.S.
2	SPINDLE	BRASS IS:319	12	HAND WHEEL	C.I. IS : 210
3	BONNET	GM IS:318 LTB 2	13	FEMALE OUTLET	GM IS:318 LTB 2
4	GLAND BUSH	GM IS:318 LTB 2	14	LOWER LUG	GM IS:318 LTB 2
5	GLAND PACKING	ASBESTOSE ROPE	15	UPPER LUG	GM IS:318 LTB 2
6	GLAND NUT	GM IS:318 LTB 2	16	BLANK CAP	PVC
7	CHECK NUT (SPINDLE)	GM IS:318 LTB 2	17	RUBBER RING	RUBBER IS:937
8	SEAT WASHER	RUBBER IS:937	18	CAM TOOTH	GM IS:318 LTB 2
9	STOP VALVE	GM IS:318 LTB 2	19	SPRING	P.B WIRE IS:7608
10	SEAT CHECK NUT	GM IS:318 LTB 2	20	CHAIN	GALVANIZED
PART LIST			PART LIST		



Shah Bhogilal Jethalal & Bros.

AHMEDABAD

TITLE :

Hydrant Valve, Single Outlet (63 mm),
Gunmetal, MMD Approved

SCALE	DRAWING NO:	SHEET	REV.
N.T.S	G104-63MM	1 OF 1	0