

HYDRANT VALVE, SINGLE OUTLET

GUNMETAL, AS PER BS:5041-1



Hydrant valves (also called Landing valves) provide the means to draw water for firefighting from the Fire water piping network. They are normally mounted onto stand posts, fitted on the fire water network.

Brief Description: Hydrant Valve, Oblique Type, as per BS: 5041-Part 1, made of Gun Metal, having 75 mm flanged inlet, and 63 mm Female Instantaneous outlet, provided with C.I. hand wheel for operation, and PVC blank cap with chain. Body duly painted with 2 coats of superior quality paint. H.P. tested to 21 kgf/cm² (body) and 14 kgf/cm² (seat). Flow 900 lpm (min) at 7 kgf/cm².

1.0 GENERAL DATA

1.1	Make	AAAG
1.2	Size	63 mm
1.3	Inlet	Flanged - 80/ 75 NB, IS: 1538 / ANSI B 16.5 150 #
1.4	Outlet	63mm Female Inst. Adaptor
1.5	Reference Standard	BS:336

2.0 MATERIAL OF CONSTRUCTION

2.1	Body, Bonnets, Female outlet and parts	G.M. BS:1400 LG2
2.2	Spindle	Brass BS:2874
2.3	Spring	Phosphor Bronze Wire
2.4	Hand Wheel	Cast Iron, BS:1452
2.5	Washer	Rubber, BS:1154

3.0 TESTING AND QUALITY CONTROL

3.1	Dimensional check	Dimensions as per SBJ Drawing (See below)
3.2	Water Tightness Seat Test	14 kgf/cm ² for 2.5 minutes.
3.3	Hydrostatic Pressure Test	21 kgf/cm ² for 2.5 minutes.
3.4	Performance requirements	Flow test : 900 lpm (min) at 7 kg/cm ² pressure
3.5	Documentation	Internal inspection report, supplier's certificates, approved laboratory test certificates

4.0 OPERATIONAL/ TECHNICAL DATA

4.1	Working pressure range	upto 10 Kg/cm ²
4.2	Weight (approx.)	9.0 Kgs.

5.0 FINISH

5.1	Body	Painted - Fire Red Color
5.2	Wheel	Painted - Black Color
5.3	Parts	Polished

6.0 APPROVALS & MARKING

6.1	Approvals	--
6.2	Marking on Hydrant valve	BHOJEBROS / Size/ Year of Manufacture/ Sl. No

7.0 WARRANTY

7.1	Warranty & Guarantee	12 Months from the date of supply
-----	----------------------	-----------------------------------

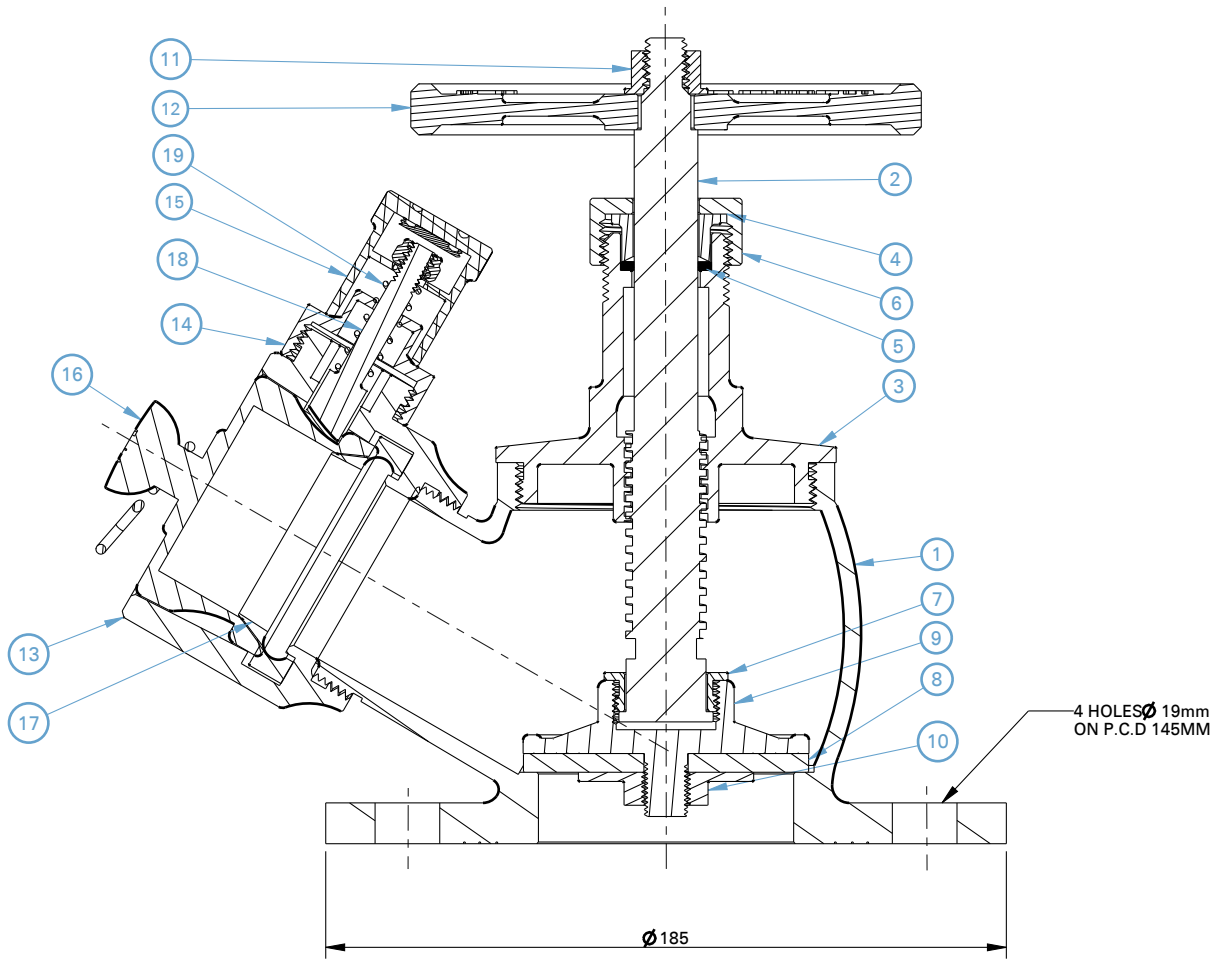

HYDRAULIC TEST:

SEAT TIGHTNESS :14KGF/CM2. (FOR 2.5 MINUTES)
 BODY :21KGF/CM2. (FOR 2.5 MINUTES)
 FLOW TEST :900 LPM MIN @ 7KGF / CM2.

1	BODY	GM BS: 1400 LG2	11	HEX.NUT	M.S.
2	SPINDLE	BRASS BS: 2874	12	HAND WHEEL	CAST IRON, BS: 1452
3	BONNET	GM BS: 1400 LG2	13	FEMALE OUTLET	GM BS: 1400 LG2
4	GLAND BUSH	GM BS: 1400 LG2	14	LOWER LUG	GM BS: 1400 LG2
5	GLAND PACKING	ASBESTOSE ROPE	15	UPPER LUG	GM BS: 1400 LG2
6	GLAND NUT	GM BS: 1400 LG2	16	BLANK CAP	PVC
7	CHECK NUT (SPINDLE)	GM BS: 1400 LG2	17	RUBBER RING	RUBBER, BS :1154
8	SEAT WASHER	RUBBER, BS :1154	18	CAM TOOTH	GM BS: 1400 LG2
9	STOP VALVE	GM BS: 1400 LG2	19	SPRING	Phosphor Bronze Wire
10	SEAT CHECK NUT	GM BS: 1400 LG2	20	CHAIN	GALVANIZED
NO.	DESCRIPTION	MATERIAL	NO.	DESCRIPTION	MATERIAL
PART LIST			PART LIST		



Shah Bhogilal Jethalal & Bros.
 AHMEDABAD

TITLE : Hydrant Valve, Single Outlet Oblique (63 mm), Gunmetal, As Per BS: 5041-1

SCALE	DRAWING NO:	SHEET	REV.
N.T.S	G104-63BS	1 OF 1	0